

INFORMATION UPDATE INFORMATION



Date: April 28, 2006
To: Multiquip LS-Series Concrete Pump Owners
From: Multiquip Product Department
Subject: **INFORMATION UPDATE – Remixer Shaft**

Our records indicate your company purchased one or more LS-Series concrete pumps. These pumps may experience problems with the remixer shaft due to the high operating pressure of the hydraulic motor relief valve set too high.

This service bulletin is an *information* service bulletin and is not mandatory. In the event the current remixer paddle shaft fractures or breaks on your pump, follow the procedures outlined in the service bulletin in installing a new modified remixer paddle shaft. The new remixer paddle shaft has been redesigned with increased durability.

IF THIS LS-SERIES PUMP HAS BEEN RE-SOLD, AS THE ORIGINAL BUYER, YOU ARE RESPONSIBLE FOR CONTACTING THE NEW OWNER AND FORWARDING THIS INFORMATION.

IF YOU DECIDE A REMIXER SHAFT MODIFICATION OF YOUR PUMP IS REQUIRED YOU MUST PLACE A PARTS ORDER WITH THE MULTIQUIP PARTS DEPARTMENT TO ENSURE PROPER SHIPMENT. Upon placing the order, the *Remixer Shaft Coupler Kit* will be shipped UPS ground.

To assure proper installation of this kit, we recommend a qualified hydraulics technician or an MQ Authorized Service Center (ASC) perform the installation. If you have any questions, or need help locating an ASC please check our website for an ASC location at www.multiquip.com.



LS- Series Concrete Pump

Following are the serial numbers of your affected units:



Service Bulletin No. CP20060428
Subject: Remix Shaft Coupler Retrofit Kit
Model: LS40D, LS40TD, LS50TD & LS60TD
Product Group: Concrete Pump
Date: April 28, 2006

SERVICE BULLETIN

Group: CP

Mandatory

Information

Recommended Change

Series/Parts Affected:

LS40D, LS40TD, LS50TD and LS60TD Concrete Pumps

Machines Affected:

<u>Model</u>	<u>Serial Number Range</u>
LS40D	S/N 2500499 AND BELOW
LS40TD	S/N 2500499 AND BELOW
LS50TD	S/N 2500499 AND BELOW
LS60TD	S/N 2500499 AND BELOW

SERVICE INFORMATION

INFORMATION UPDATE: The hopper remixer shaft has been redesigned to improve durability. The original shaft has been discontinued. Should you experience a remixer shaft fracture or wish to modify your current remixer shaft, please follow the modification procedure contained within this service bulletin.

Problem:

- Remix shaft fractures are occurring on some LS-series concrete pumps. Probable cause for this failure is the operating pressure of the hydraulic motor relief valve may be set too high.

Solution:

- Install LS-Series Remix Shaft Coupler Retrofit Kit (P/N EM516833)

PARTS INFORMATION

Quantity	Part #	Description	Remarks
1	EM516833	LS-Series Remix Shaft Coupler Retrofit Kit	

INSTALLATION INSTRUCTIONS

WORK SAFELY!

Only a **qualified service technician** with proper training in hydraulics should perform this installation.

NEVER! open the hydraulic lines or loosen fittings while the engine is running! Hydraulic fluid under pressure (**hot!**) can penetrate skin causing severe burns, eye injuries and other potentially dangerous hazards. **ALWAYS** follow safety guidelines.



Required Tools/Materials

- 3/8”/1/2” Allen Wrench w/ 3/8” drive
- 3/16” Allen Wrench
- 3/4” Combination Wrench
- 3/4” Socket w/ 3/8” Ratchet
- 3/8” Extension (6-inches)
- 3/8” Pivot Ratchet
- 7/8” Open-End Wrench
- Small Pry Bar (2)
- Flat Head Screwdriver
- Hammer, Ball-Pean
- Snap Ring Pliers (Standard Heavy Duty)
- Snap Ring Pliers (Light Duty)
- Loctite # 242 Blue
- Electric Drill w/15/64 Drill Bit

Please make sure all retrofit kit parts are accounted for. See Table 1.

Table 1. Retrofit Kit Parts List

Part Number	Description	Quantity
516775	Motor Shaft Coupling	1
516787	Remixer Shaft Coupling	1
516776	Drive Member Coupling (Thin Union)	1
702	3/8” Dog Point Allen Head Set Screw	1
492470	3/8” Standard Allen Head Set Screw	3
EM511428	Allen Head Bolt 1/2 x 3-1/2	4
EM500264	Square Key 3/8”x 30 mm	1
EM516799	6 mm Spacer	1
EM516779	Remixer Shaft	1
EM516820	Compression Springs	2
EM200301	Graphite Seals	6
EM516780	Bearing Housing	1

Safety Procedures

Perform the following before attempting installation retrofit kit:

1. Place the machine on level secure ground that is free of dirt and debris.
2. Wear safety glasses; steel toed boots and any other safety protection that might be required for the modification.
3. Disconnect the negative battery cable from the battery.
4. Remove the ignition key from the switch.

Verify that all pressure gauges read zero.

Disassembly of Hopper Remix Shaft and Components

Reference Figure 1

1. Using 5/8" and 9/16" size wrenches, remove the four bolts (item 1) and associated hardware that secure the hopper grate to the hopper. **NOTE:** some units may only have 2 bolts.
2. Remove the six paddle arms (item 2) from the remixer shaft (item 12) using 3/4" wrench. **NOTE:** mark the orientation of each paddle arm for reassembly.
3. Using a 7/8" wrench, remove the two hydraulic hoses (item 3) located on the hydraulic motor. Cap or plug the open ports on both the hydraulic motor and hoses to prevent dirt and contamination from entering the hydraulic system. **NOTE:** it may not be necessary to disconnect the hydraulic hose lines.
4. Using 3/8" wrench, remove the two hydraulic motor attachment bolts and washers (item 4) that secure the motor to the hopper. Remove the hydraulic motor by placing two pry bars in front of the motor flange and pry backwards.
5. On the hydraulic motor side of the hopper, remove the shaft set collar (item 5). Discard shaft set collar it will not be used again.
6. Using snap ring pliers (small), remove shaft snap ring (item 6) from the remixer shaft. Discard snap ring it will not be used again.
7. Using 1/2" allen head wrench remove the four bolts (item 7) from the bearing support assembly (item 8). Remove the bearing assembly with puller or by placing pry bars between the hopper and housing slowly prying backwards. **NOTE:** discard the four bolts they will not be used again.
8. On the hydraulic motor side of the hopper, using snap ring pliers (large), remove and retain bearing snap ring (item 8A) from bearing support housing. Next, use a light press or brass punch and remove the bearing (item 8B) from the bearing support housing. Retain this bearing. Take care not to damage bearing. Discard the bearing support housing (item 8C) it will not be used again. **NOTE:** items 8A and 8B will be installed on the new remixer shaft.
9. On the opposite side of the hopper (no hydraulic motor), remove the end cap (item 9). To remove end cap, use two pry bars and slightly pry backwards to remove.
10. Again, on the opposite side of the hopper (no hydraulic motor), remove the shaft set collar (item 10), and bearing support assembly (item 11). **NOTE: DO NOT** remove bearing from bearing housing.
11. Remove remixer paddle shaft (item 12) and all associated shaft components (item 13) from the hopper. These components consist of graphite seals, compression springs, spring seats and steel follower rings. The compression springs, remixer paddle shaft, and graphite seals will not be used again and should be discarded.

FIGURE 1 DISASSEMBLY OF HOPPER MIXER SHAFT

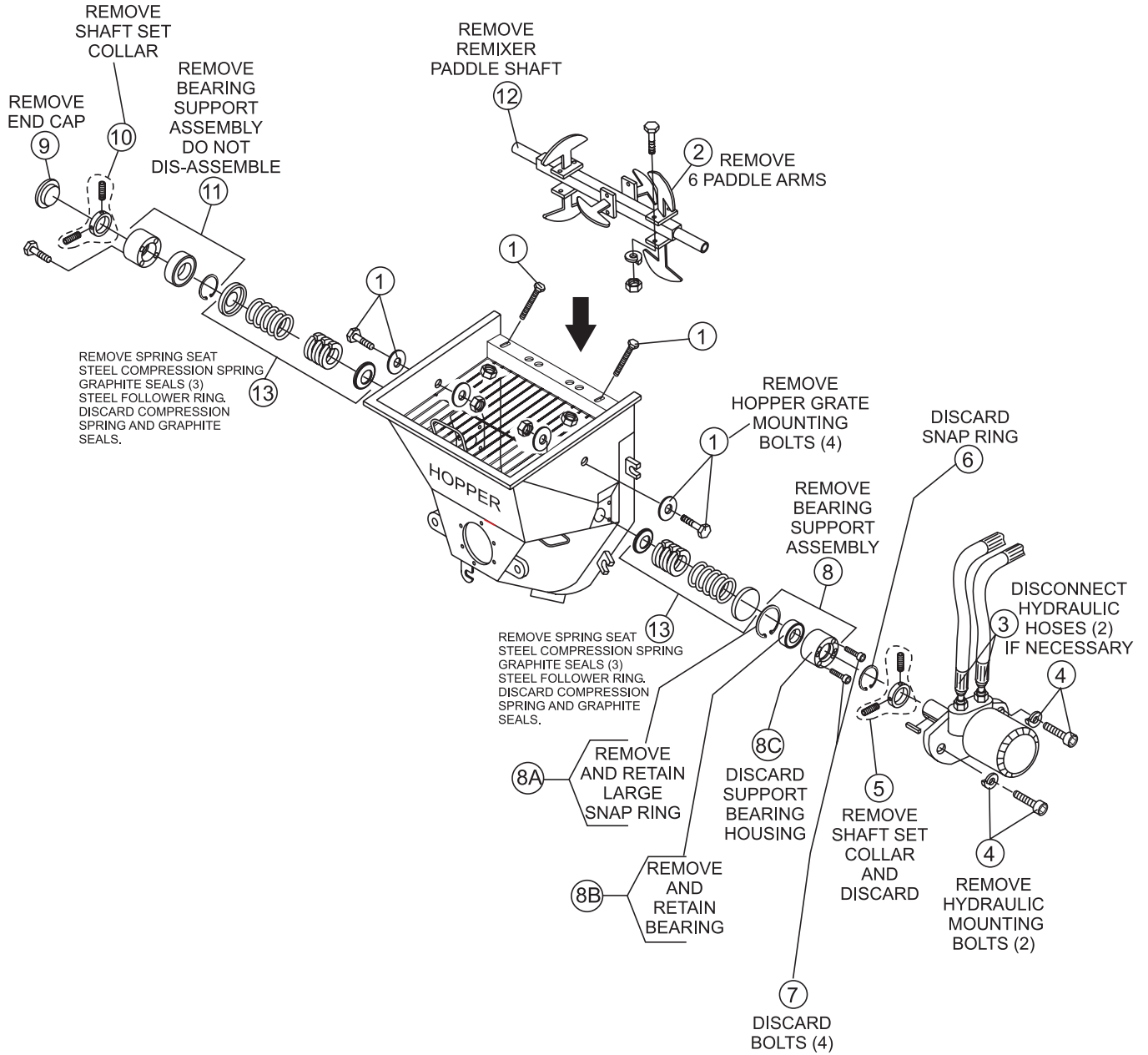

New Shaft Installation (Hydraulic Motor Side)

Reference Figure 2

The new shaft installation will include the installation of the following components:

- Steel Follower Ring
 - 3 Graphite Seals
 - New Steel Compression Spring
 - Spring Seat
 - Bearing Housing/Bearing (new)
1. Place the **new paddle shaft** (item 1) inside the hopper. The shaft end with the 3/8" key should be placed on the hydraulic motor side. Make sure the shaft is equally spaced on each side of the hopper.
 2. Starting with the hydraulic motor side of the hopper, install the **steel follower ring** (item 2) into the seal box. The beveled side should face towards inside the hopper. The seal box is part of the hopper.
 3. Liberally coat **3 graphite seals** (item 3) with automotive waterproof grease. **NOTE:** only three graphite seals are required per each side of the hopper, making a total of six seals for an entire hopper.
 4. Using a flat-blade screwdriver carefully install the first seal (item 4) into the seal box. Make sure the angle groove of the seal (cut) does not over lap. Both ends of the seal should be flush. Next, install the second seal, the (cut) groove should be placed 180 degree opposite the first seal. Next, install the third seal, the angle (cut) to be placed 90 degree from the second seal. Fill the remaining cavity area with extra grease. **NOTE: all three seal angle cuts should be staggered from one another and should not line up.**
 5. Install the **new compression spring** (item 5) into the seal cavity. **NOTE:** the new compression spring tension has less tension than the old one. This reduction in spring tension will increase seal life.
 6. Next, install the **spring seat** (item 6) making sure the seat side (indentation) is facing the compression spring.
 7. Install the **new replacement bearing housing** (item 7). on the hydraulic motor side. Place existing bearing (item 7A) into bearing housing by pressing or lightly tapping into position. Take care not to damage the bearing and make sure it is properly seated. Using snap ring pliers (standard heavy duty) install snap ring (item 7B) to retain bearing inside housing. **NOTE:** The bearing and snap ring were removed earlier in the disassembly procedure.
 8. Install the bearing support assembly (item 8) over the paddle shaft. Tap bearing support assembly into position. **NOTE:** The snap ring (item 7B) side of the bearing support assembly should face the hopper side. **IMPORTANT!**, the three small holes located on the side of the bearing support assembly, should face downward towards the ground.
 9. Install the four 1/2" allen head bolts (item 9) that secure the housing to the hopper. These four bolts should only be hand tightened at this time.

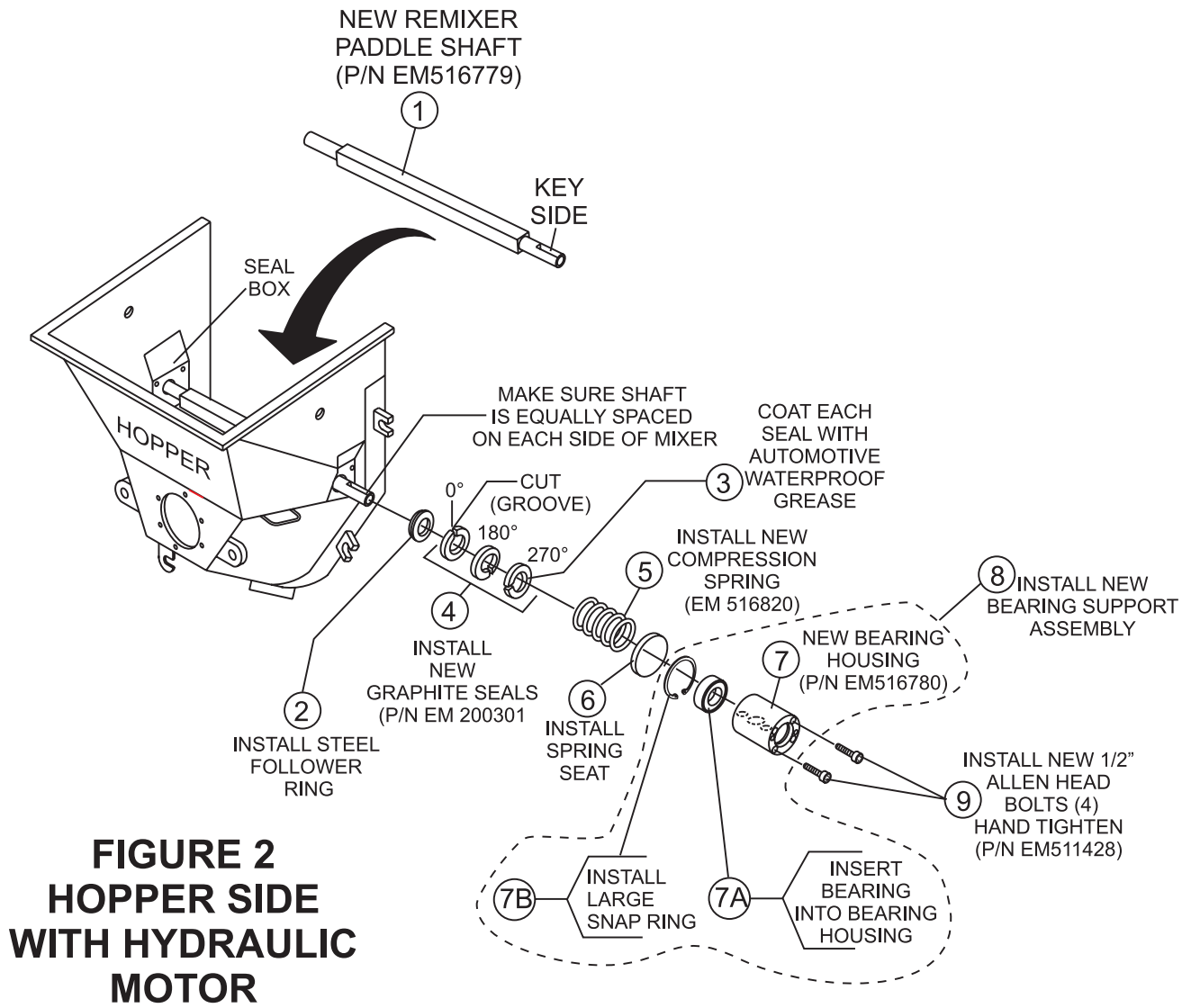

New Shaft Installation (Side without Hydraulic Motor)

Reference Figure 3

The new shaft installation will include the installation of the following components:

- Steel Follower Ring
 - 3 Graphite Seals
 - New Steel Compression Spring
 - Spring Seat
 - Bearing Housing/Bearing (existing)
1. Install the **steel follower ring** (item 1) into the seal box. The beveled side should face towards inside the hopper. The seal box is part of the hopper.
 2. Liberally coat **3 graphite seals** (item 2) with automotive waterproof grease.
 3. Using a flat-blade screwdriver carefully install the first seal (item 3) into the seal box. Make sure the angle groove of the seal (cut) does not over lap. Both ends of the seal should be flush. Next, install the second seal, the (cut) groove should be placed 180 degree opposite the first seal. Next, install the third seal, the angle (cut) to be placed 90 degree from the second seal. Fill the remaining cavity area with extra grease. **NOTE: all three seal angle cuts should be staggered from one another and should not line up.**
 4. Install the **new compression spring** (item 4) into the seal cavity.
 5. Next, install the **spring seat** (item 5) making sure the seat side (indentation) is facing the compression spring. **NOTE:** the compression spring specification was changed to relieve tension to increase seal life.
 6. Install the existing bearing support assembly (item 6) over the paddle shaft. Tap bearing support assembly into position. **NOTE:** The snap ring side of the bearing support assembly should face the hopper side.
 7. Install the four 1/2" allen head bolts (item 7) that secure the bearing support assembly to the hopper. These four bolts should only be hand tightened at this time.

Verification of Shaft Installation

On each side of the remixer shaft, verify that the steel follower ring, graphite seals, compression spring, spring seat and bearing housing have been installed and are aligned correctly. If the shaft installation has been verified and found to be acceptable, tighten securely the 1/2" bearing support assembly mounting bolts, four on each side.

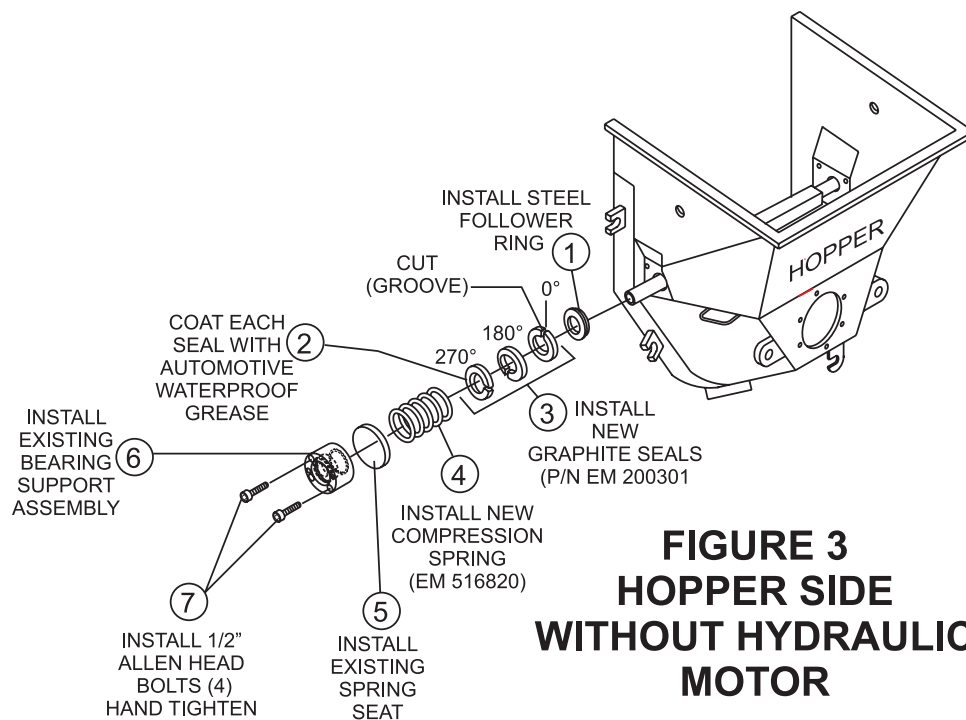

**FIGURE 3
HOPPER SIDE
WITHOUT HYDRAULIC
MOTOR**

Remixer Shaft Coupler Installation

Reference Figure 4

Please note that the coupler is comprised of three individual sections. They are remixer shaft coupler, drive member coupler (thin center) and hydraulic motor shaft coupler.

1. On the hydraulic motor side hopper, place a 6 mm spacer (item 1) onto the remixer shaft.
2. Install the remixer shaft coupler (item 2) onto the remixer shaft. **NOTE:** use a crescent wrench to rotate the remixer shaft until the remixer shaft coupler set screw holes are facing downward.
3. Slowly tap the remixer shaft coupling onto the remixer shaft until the coupler set screw holes becomes visible thru the 2 holes located on the bearing support assembly. It may be necessary to slightly move (tap) the shaft laterally. **DO NOT** install the coupler too deep onto the shaft. The end of the shaft must be even or slightly below the bottom of the coupler groove. After the coupler has been positioned correctly, tap $3/8$ " key (item 3) into position.
4. Once the coupler has been properly aligned onto the remixer shaft, using the 2 holes on the bearing support assembly (holes on remier shaft coupler should be aligned) as a guide, drill one hole into the remixer shaft $1/4$ " deep using a $15/64$ drill bit. This hole will counter sink the dog point set screw. **NOTE:** use the hole closest the hopper on the bearing support assembly when drilling the hole. **DO NOT** drill into the keyway.
5. Using an allen wrench, insert a $3/8$ " **dog point** set screw through the left most hole on the bearing support assembly. Apply Loctite # 242 Blue to set screw and tighten securely.
6. Using an allen wrench, insert a $3/8$ " **standard** set screw through the right most hole on the bearing support assembly. Apply Loctite # 242 Blue to set screw and tighten securely.

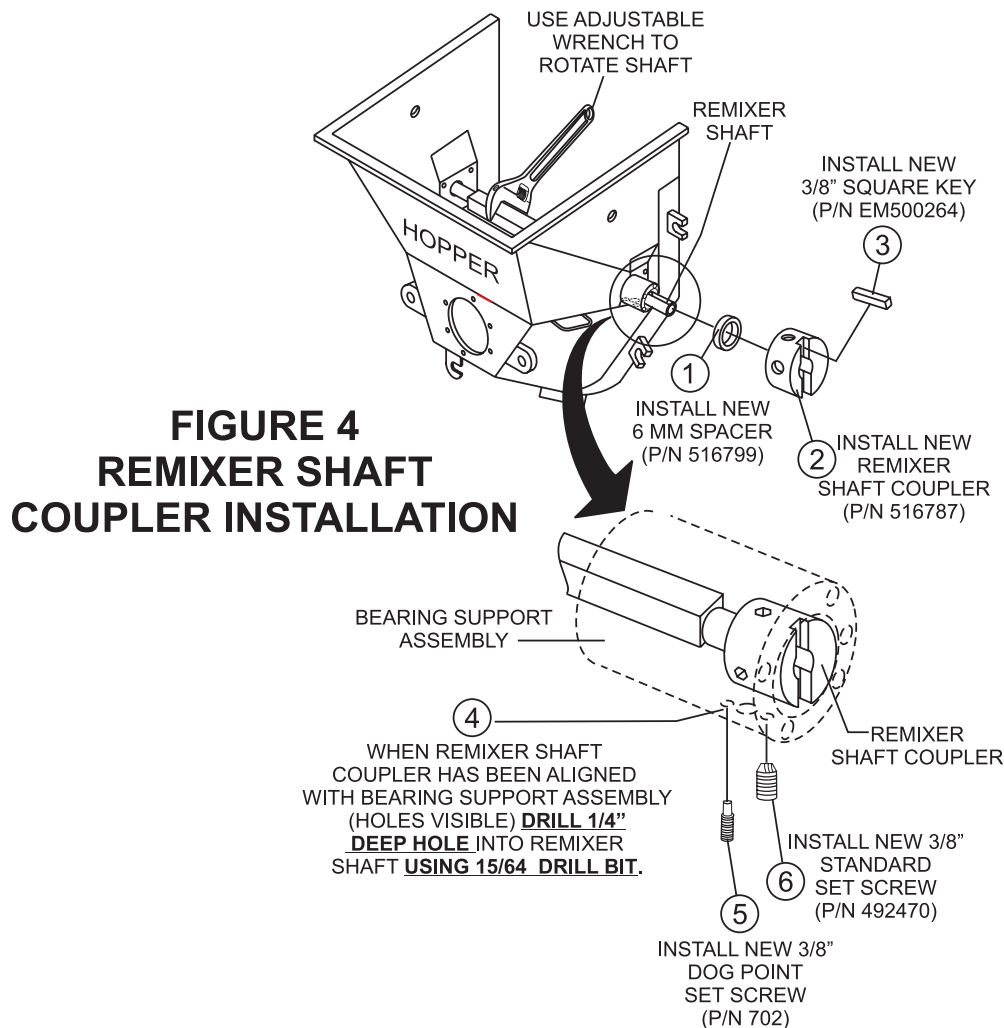

Hydraulic Motor Shaft Coupler Installation

Reference Figure 5

1. Place hydraulic motor shaft coupler (item 1) onto the hydraulic motor shaft. Again make sure the coupling is not placed too deep. The hydraulic motor shaft should be even or below the bottom groove of the coupler.
2. Insert and install 3/8" square key (item 3).
3. Using an allen wrench, insert two 3/8" set screws into the hydraulic motor shaft coupler. Apply Loctite # 242 Blue to each set screw and tighten securely.

**FIGURE 5
HYDRAULIC MOTOR SHAFT
COUPLER INSTALLATION**

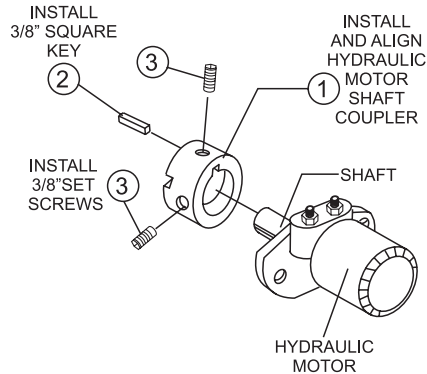

Hydraulic Motor Mounting Installation

Reference Figure 6

1. Insert and align the keyway on the drive member coupler (item 1) with the slotted groove on the remixer shaft coupler (item 1A). Make sure the keyway on the drive member coupler is seated correctly and not skewed.
2. Next, align the slot on the hydraulic motor shaft coupler (item 2), with the keyway on the drive member coupler (item 1). All couplers are keyed or slotted and must be aligned in order to fit correctly.
3. To secure the hydraulic motor to the hopper, install and tighten the two 3/8" hydraulic motor bolts (item 3).
4. To check coupling alignment, use a flashlight and look through the large center hole (item 4) at the bottom of the bearing support assembly to verify that the coupler drive member (thin center coupler) has been mated correctly and is not misaligned.

**FIGURE 6
REMIKER SHAFT
COUPLER INSTALLATION**

