



MULTIQUIP

Street Pro Slab Saws



**Versatile saws for
demanding cutters**

Construction Starts Here

www.multiquip.com



Street Pro Slab Saws



Made in U.S.A.

Multiquip's Street Pro Series of walk-behind saws is designed for trusted durability, simple operating mechanics and cutting performance. Whether cutting concrete or asphalt, the reinforced steel box frame style adds strength necessary to reduce vibrations while sawing. Minimizing vibrations enhances the tracking and

sawing performance of the diamond blade. Constructed for easy maintenance, the Street Pro Series utilizes standardized hardware, heavy-duty components, and easy access design. The saws are easy to operate, yet demonstrate the cutting performance usually expected from larger, more expensive units.

Street Pro SP1

Gasoline Model



Always wear approved safety equipment and clothing when operating this machine.

The rugged SP1 is economical, compact, and easy to operate.

Saws Built to Perform



Street Pro SP2

The SP2 is an exceptional performing saw. Models include a choice of Honda GX390 or GX620 gasoline engines, and either Push or Self-propelled operating design. The SP2 comes standard with 20" (508mm) blade capacity permitting a 7.5" (191mm) depth of cut.

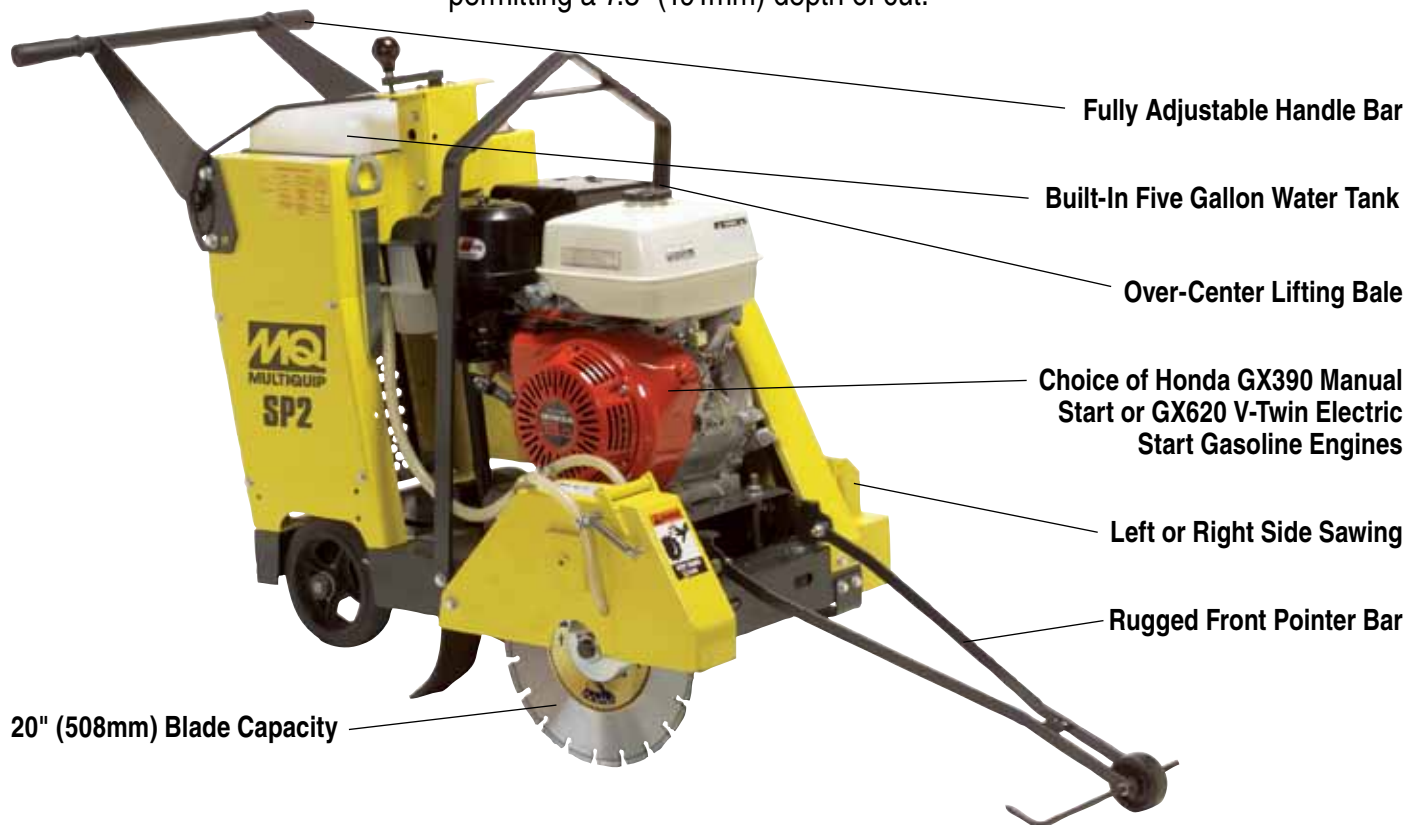

Trusted Hydrostatic Transmission Propulsion and Free-Wheel System on Self-Propelled Models

Removeable Hinged 20" (508mm) Blade Guard

Industrial Blade Shaft Assembly



Always wear approved safety equipment and clothing when operating this machine.

Street Pro Slab Saws – Specifications



Model	Power*	Weight lbs. (kg)	Blade Capacity in. (mm)	Cutting Depth in. (mm)	Front Wheels Bearing Mounted	Rear Wheels Bearing Mounted
SP1 Series Push						
SP118	11.0 HP (9.7 kW) Honda Cyclone	270 (122.7)	18 (457)	6.5 (165)	4" Dia. x 2" Wide (101mm x 50mm)	8" Dia. x 2" Wide (203mm x 50mm)
SP15E16	5.0 HP (3.7 kW) Elect. 230V 1ø	235 (106.8)	16 (406)	5.5 (140)	4" Dia. x 2" Wide (101mm x 50mm)	6" Dia. x 2" Wide (152mm x 50mm)
SP2 Series Push						
SP213H20A	11.0 HP (9.7 kW) Honda Cyclone	280 (127)	20 (508)	7.5 (191)	5" Dia. x 2" Wide (125mm x 50mm)	8" Dia. x 2" Wide (203mm x 50mm)
SP2 Series Self-Propelled						
SP2S13H20A	11.0 HP (9.7 kW) Honda Cyclone	280 (127)	20 (508)	7.5 (191)	5" Dia. x 2" Wide (125mm x 50mm)	8" Dia. x 2" Wide (203mm x 50mm)
SP2S20H20A	18.0 HP (14.9 kW) Honda Cyclone Elect. Start	400 (181.8)	20 (508)	7.5 (191)	5" Dia. x 2" Wide (125mm x 50mm)	8" Dia. x 2" Wide (203mm x 50mm)

© COPYRIGHT 2009, MULTQUIP INC.

Saw Accessories

Model	Description	Weight lbs. (kg)
SP1WK	Water Tank Kit, SP118 (gas only)	25 (11)
SPBG16A	Blade Guard Kit (models SP1 & SP2)	25 (11)
SPBG18A	Blade Guard Kit (models SP1 & SP2)	27 (12)
SPBG20A	Blade Guard Kit (model SP2 only)	30 (14)

Multiquip guarantees diamond blade performance!



Multiquip offers a variety of trusted diamond blade choices that provide the best return on your investment. Call or visit our web site for more information.

Always wear approved safety equipment and clothing when operating this machine.

* Engine power ratings are calculated by the individual engine manufacturer and the rating method may vary among engine manufacturers. Multiquip Inc. and its subsidiary companies makes no claim, representation or warranty as to the power rating of the engine on this equipment and disclaims any responsibility or liability of any kind whatsoever with respect to the accuracy of the engine power rating. Users are advised to consult the engine manufacturer's owners manual and its website for specific information regarding the engine power rating.

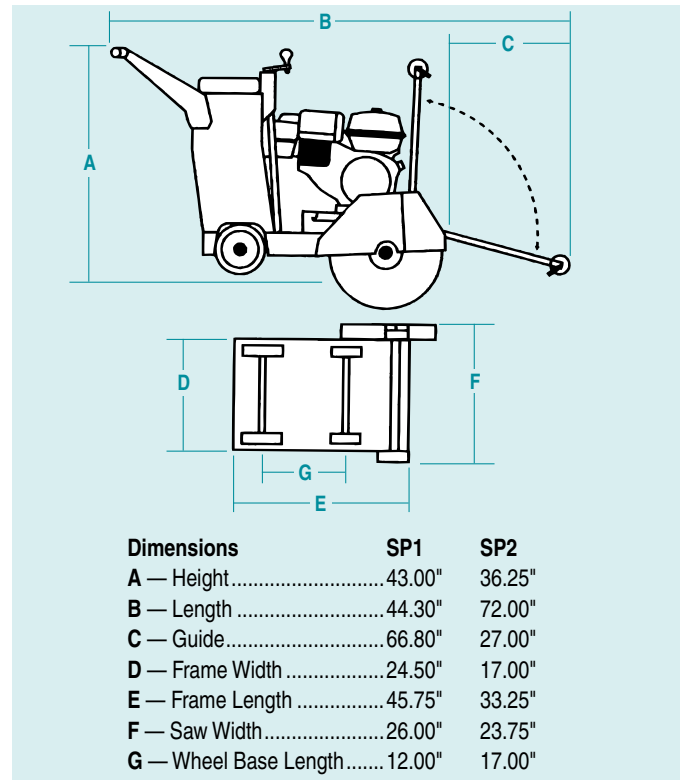

MULTIQUIP INC.
 POST OFFICE BOX 6254
 CARSON, CA 90749
 310-537-3700 • 800-421-1244
 FAX: 310-537-3927
 E-MAIL: mq@multiquip.com
www.multiquip.com